



**AV25-2 NET Series**

**Owner's Manual  
April 2016**

[www.stewartaudio.com](http://www.stewartaudio.com)

# Important Safety Instructions

Before using your Stewart Audio Inc. Power Amplifier, please read this **Owner's Manual** carefully to ensure optimum trouble-free performance.

**WARNING: TO REDUCE THE RISK OF ELECTRICAL SHOCK, DO NOT EXPOSE THIS AMPLIFIER TO RAIN OR MOISTURE. DANGEROUS HIGH VOLTAGES ARE PRESENT INSIDE THE ENCLOSURE. DO NOT OPEN THE CABINET. REFER SERVICING TO QUALIFIED PERSONNEL ONLY.**

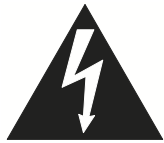
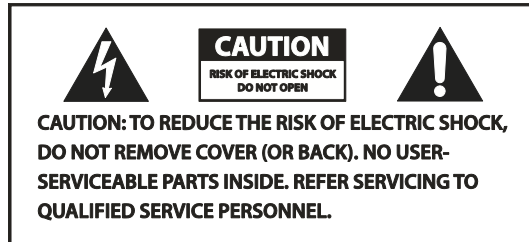

The lightning bolt within arrowhead symbol, within an equilateral triangle, is intended to alert the user to the presence of un-insulated “dangerous voltage” within the product’s enclosure that may be of sufficient magnitude to constitute a risk of electrical shock to person.



The exclamation point within an equilateral triangle, is intended to alert the user to the presence of important operating and maintenance (servicing) instruction in the literature accompanying the appliance.

## Important Safety Instruction – Please Read Prior to Product Installation.

1. Installation should be performed by a trained and licensed professional to insure safe and lasting operation.
2. All of the safety and operating instructions should be read before the amplifier is installed or operated. Retain these instructions for future reference. All instructions should be followed; all warnings on the amplifier and in the operating instructions should be adhered to.

3. The amplifier should be situated so that its location and position does not interfere with its proper ventilation. For example, the amplifier must not be placed on a rug, bed, sofa or similar surface that impedes airflow across the chassis. Airflow through the ventilation openings should be unobstructed.
4. This amplifier should not be used near water, for example, near a bathtub, in a wet basement, near a swimming pool, etc. This amplifier is intended to be operated in a controlled indoor environment.
5. Do not place the amplifier near heat sources such as radiators, heat registers, stoves, or other appliances that produce heat.
6. The amplifier should only be connected to 120 VAC, 60 Hz power supply. Do not defeat the ground or polarization of the power plug.
7. Route power cord and other cables so that they are not likely to be walked on, tripped over or stressed. Pay particular attention to condition of cords and cables at plugs and at the point where they exit the amplifier. To prevent risk of fire or injury, damaged cords and cables should be replaced immediately.
8. Clean the amplifier with a clean, damp cloth. Do not use solvents or abrasive cleaners. Never pour any liquid on the amplifier.
9. When left unused for a long period of time, the power cord should be unplugged from the outlet.
10. Damaged Amplifiers requiring service should be repaired by a qualified service technician when:
  - a. The power cord or AC plug has been damaged.
  - b. Objects have fallen, or liquid has spilled into the unit.
  - c. The amplifier has been exposed to rain or other moisture.
  - d. The amplifier does not appear to operate normally or exhibits a marked change in performance.
  - e. The amplifier has been dropped or the enclosure damaged.
11. The user should not attempt to service the amplifier beyond that described in the operating instructions. All other servicing should be referred to qualified service personnel.

# Table of Contents

Important Safety Instructions.....	2
Table of Contents .....	4
<b>1 Welcome</b> .....	5
1.1 Features.....	5
1.2 Using this Manual .....	5
<b>2 Setup</b> .....	6
2.1 Setup Precautions .....	6
2.2 Amplifier Installation .....	6
2.3 Proper Cooling Considerations .....	8
2.4 Input Connections .....	9
2.5 Output Connections .....	11
<b>3 Operation</b> .....	13
3.1 Operation Precautions.....	13
3.2 Controls, Indicators, and Connectors .....	14
3.3 Dante.....	17
3.4 Remote Volume Control.....	19
<b>4 Troubleshooting</b> .....	20
<b>5 Technical Specifications</b> .....	21
<b>6 Warranty Information</b> .....	22
6.1 Warranty Summary .....	22
6.2 Return Procedure .....	22
<b>7 Accessories</b> .....	25
<b>8 Notes</b> .....	26



***This amplifier proudly designed and manufactured in the USA.***

# 1 Welcome



Congratulations on the purchase of your new Stewart Audio AV Series power amplifier. This amplifier has been designed and built to provide you with years of high-quality audio performance and trouble-free operation. If after reading this manual you should have any questions concerning amplifier installation and operation, please contact your Authorized Stewart Dealer, or you may contact us directly using the contact information provided on the back of this manual.

## 1.1 Features

Your Stewart Audio AV Series amplifier is the result of years of experience in the design and manufacture of quality amplifiers. As such it provides a combination of performance and operational benefits that simply cannot be found in conventional amplifiers.

- Sub Compact 1/3 rack package
- Two channel networked amplifier, optimized to drive 4 Ohm and 8 Ohm loads
- Selectable priority switching on NET+ models
- Clean full-range dynamic power
- Signal Detect trigger for sleep & wake up
- Multiple mounting options
- Made in the USA

## 1.2 Using this Manual

In order to obtain maximum performance from your AV Series Amplifier, please take time to read this brief owner's manual and carefully follow the guidelines for connection and operation.

This manual provides you with the information necessary to safely install and operate your new AV Series amplifier in the most common scenarios. If you find yourself requiring additional assistance, please feel free to contact your Authorized Dealer, or you may contact us directly using the contact information provided on the back of this manual.

## 2 Setup

### 2.1 Setup Precautions

 **CAUTION:** Before installing your amplifier, make sure that you have read the Important Safety Precautions at the beginning of this manual.

### 2.2 Amplifier Installation

The AV25-2 NET series incorporates a number of different mounting options in order to fit your installation needs.

#### 2.2.1 Pole-Mounting

The AV Series of amplifiers is Stewart Audio's first line of pole-mountable amplifiers. The AV25-2 NET series has mounting holes on the top of the unit which can be used with the AV-Pole bracket available from Stewart Audio.



Part Number: AV-Pole

#### 2.2.1 Universal-Mount Installation

The AV25-2 NET series also has a universal bracket available which allows the unit to be mounted against a wall or under a table. Two screws are included in the kit which will affix the bracket to the top or the side of the unit. Once this is done, two holes are available for mounting the unit where desired.

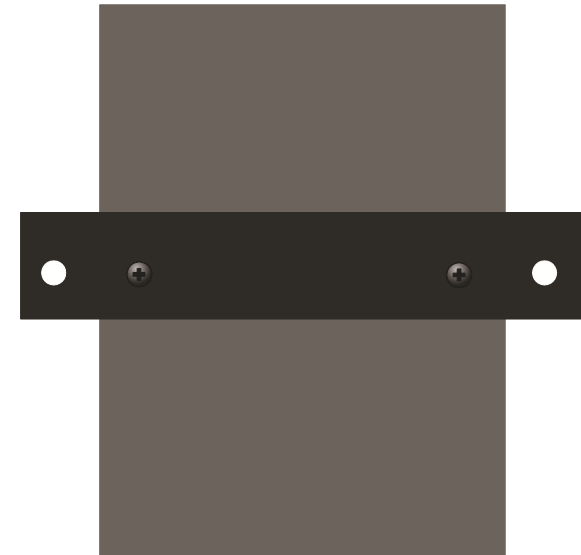

Part Number: AV-Bracket

 **CAUTION:** Use only the screws provided in mounting brackets to the amplifier. Do not over tighten.

## 2.4.2 Unbalanced Input Connections

When using an unbalanced input source and connector, a jumper must be added between the negative (-) terminals and the ground terminals. Once this has been done, the unbalanced source can be connected to the positive (+) and ground terminals. Please refer to the manual of your input source in case it does not follow the standard pin-out. For your convenience, pre-wired connectors are available for purchase, see the next page for details.

**NOTE:** A jumper is *required* for connecting an unbalanced input.

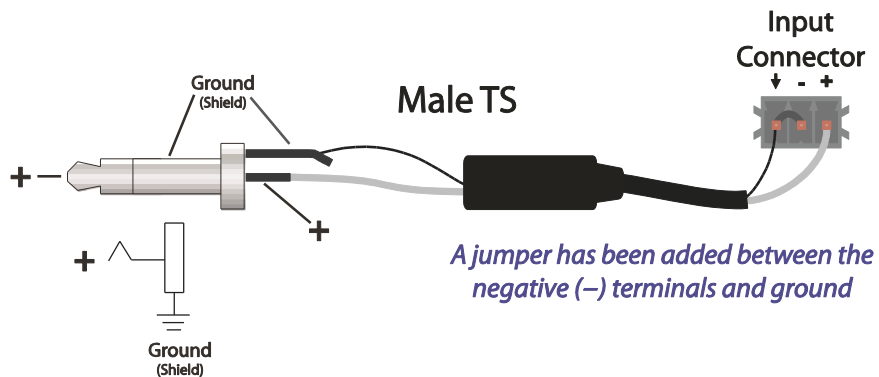
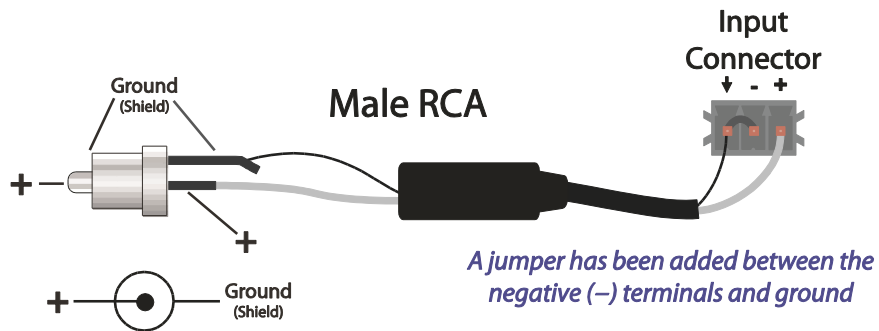

**NOTE:** The AV25-2 Series of amplifiers do not accept stereo inputs. Either one side must be selected from the stereo source or an overload-protected Y-cable must be used to sum them to mono. It is highly recommended that you purchase the pre-wired connectors mentioned on the next page. Damage to source equipment can result from the use of a standard Y-cable.

Pre-wired unbalanced connectors are available for purchase from Stewart Audio. These will allow for a quicker installation with less room for error when connecting the CVA Series amplifier to an unbalanced source. The summing adapters will properly sum a stereo source for use with the mono input on the rear of the amplifier without causing sound cancellation. Part numbers are found below the diagrams.

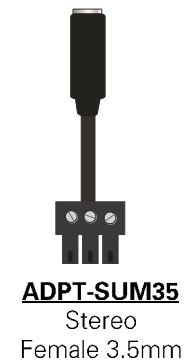
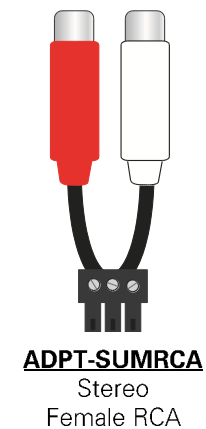
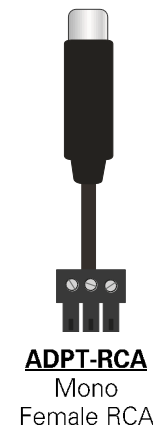

## 2.5 Output Connections

Stewart Audio recommends using high-quality, heavy-gauge speaker wire and connectors to send the output signal of your amplifier to the speakers. Use the following table as a guideline when selecting your wire gauge.

Distance	Wire Gauge
Up to 25 ft.	16 AWG
26-40 ft.	14 AWG
41-60 ft.	12 AWG

Speaker leads connect by means of terminal block connectors supplied with the unit. Strip speaker leads 1/4" and insert into connector observing proper polarity. With a small, flat-blade screwdriver, tighten the screw until the leads are held securely in place. Inspect for possible shorts or broken wires.

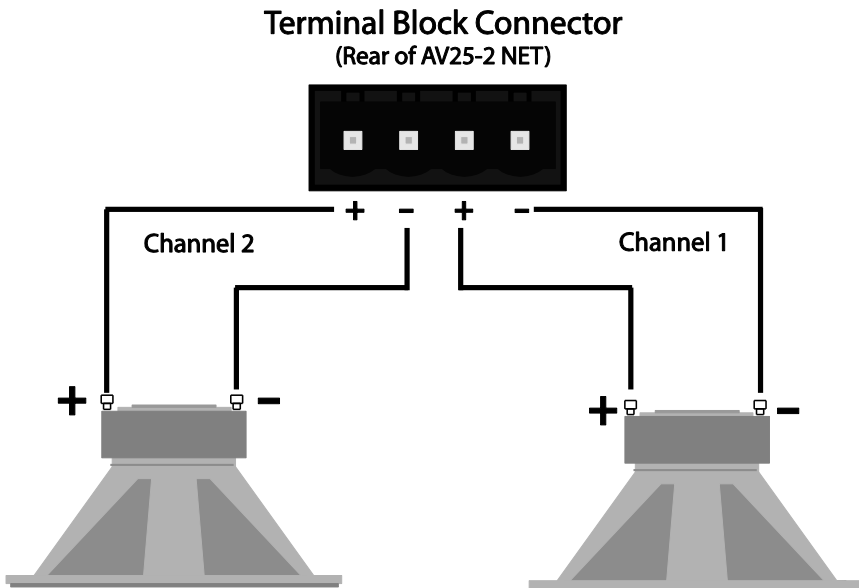

## 3 Operation

### 3.1 Operating Precautions

1. Before use, your amplifier must be configured for proper operation, including input and output wiring hookup. Improper wiring can result in damage to equipment or potentially harm to the operator. Consult section 2 for setup instructions.
2. Tampering with the circuitry, or making unauthorized changes is not only dangerous but may also violate local regulations.
3. Use care when making connections between the amplifier and the input or output equipment. Using equipment that is not capable of handling the output wattage may lead to permanent damage.



**NOTE: Stewart Audio will not be held responsible for damage to your AV25-2 NET series amplifier or connected equipment if the instructions in this manual are not followed.**

## 3.2 Controls, Indicators, and Connectors

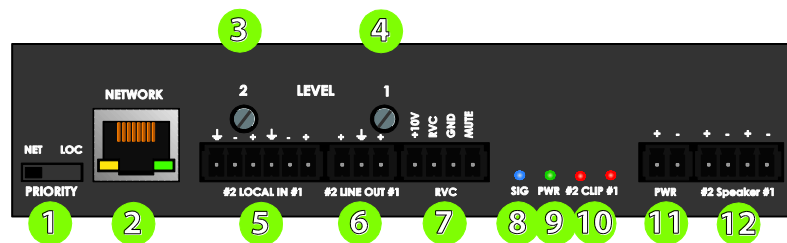

- |                          |                                |
|--------------------------|--------------------------------|
| 1 Signal Priority Switch | 7 Remote Volume Control        |
| 2 Network Connector      | 8 Signal Present Indicator LED |
| 3 Channel 2 Level Knob   | 9 Power Indicator LED          |
| 4 Channel 1 Level Knob   | 10 Clip Indicator LEDs         |
| 5 Input Connector        | 11 Power Connector             |
| 6 Line Out               | 12 Speaker Out Connector       |

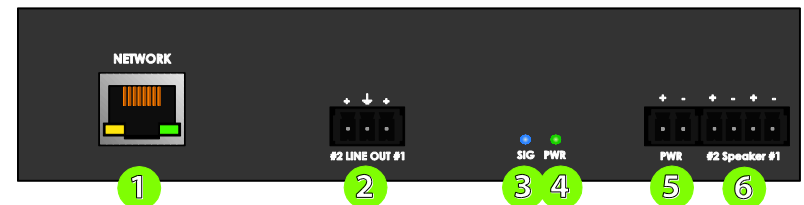

- |                                |                         |
|--------------------------------|-------------------------|
| 1 Network Connector            | 4 Power Indicator LED   |
| 2 Line Out                     | 5 Power Connector       |
| 3 Signal Present Indicator LED | 6 Speaker Out Connector |

### 3.2.1 Indicators

The AV25-2 NET series has up to 4 rear panel LED indicators. The first is the power indicator which will illuminate when power is supplied to the amplifier. The second light is the signal present LED which will illuminate when signal is detected on either one of the input connection channels. The final 2 LED indicators (only on the NET+ models) are the "Clip" indicators, one for each channel. These lights will indicate that the input signal is too "hot" and will sound distorted when amplified. To fix this, the gain should be reduced at the preamp or mixer level.

### 3.2.2 Controls (NET+ Models Only)

All AV25-2 NET+ controls are located on the rear of the unit. There is no power switch so the AV25-2 NET+ will turn on whenever power is supplied to it.

**The level controls adjust the level of the local input signals only. They do not adjust the Dante network audio signal level. This level must be adjusted at the signal source or via a network audio device.** The rear panel contains two individual channel level knobs. The amplifier is set to run off of a line-level source. Adjust the levels with a small flat-head screwdriver to the desired listening level. The minimum signal level results from turning the level screw fully counterclockwise; the maximum level results from turning the level screw fully clockwise.

### 3.2.3 Signal Priority Switching (NET+ Models Only)

The AV25-2 NET+ amplifier includes selectable priority switching which allows either the network or local input to override the other input depending on the switch setting. The switch position should be set to the priority input – the signal that will interrupt the "normal" program. When audio is detected on that priority input the amplifier will mute the signal from the other ("normal") input. After an approximately 3.5 second period with no signal on the priority channel, the "normal" signal will be un-muted. For example, if a local microphone is to be used as a priority page, set the priority switch to "Local". When a microphone signal is detected the "normal" network audio will be muted and the page will come through

## 3.3 Dante

If you have selected the Dante version of the AV25-2 NET series, configuration is done using the Dante Controller software from Audinate.

**Dante Controller Software can be found on Audinate's website at [www.audinate.com](http://www.audinate.com).**

From there you can select Dante Controller under the Products section. This will require registration for Audinate's portal and also includes access to the Dante Controller User Manual which should be read for complete configuration instructions.

### 3.3.1 Using Audinate's Dante Controller Software

Once Dante Controller has been installed following the instructions in the Dante Controller Software User Manual (found at [www.audinate.com](http://www.audinate.com)), launch the application to see the connection matrix.

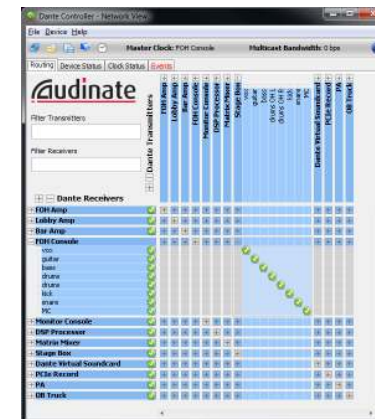

Unlike CobraNet, Dante does not require IP configuration or bundle configuration. Instead, connections are made on the connection matrix shown above



**All Stewart Audio products will ship from the factory as being named Ultimo-<MAC>. This can be renamed within the device configuration in the Dante Controller.**

Transmitters are shown on the top of the matrix while Receivers are shown on the left-hand side. The AV25-2 NET series includes 2 transmitters and 2 receive channels. In order to make a connection, click on the matrix node between the appropriate transmitter and receiver. If a connection is successful, it will display a green checkmark.

### 3.3.2 Dante FAQ

*Q: I am having problems installing or using the Dante Controller Software*

A: Please refer to the official documentation available in the Audinate portal where you downloaded the Controller Software.

*Q: I do not see the AV25-2 NET series showing up on the network?*

A: All Stewart Audio products are tagged as Ultimo-<MAC\_ADDRESS> from the factory. You can find the correct Ultimo device by choosing the correct MAC address from the list. You can rename this using the device configuration.

### 3.4 Remote Volume Control (NET+ Models Only)

AV25-2 NET+ amplifiers can have their volume remotely controlled (or muted) via the Euro Block input on the rear of the amplifier. The remote volume control allows the units volume to be controlled through the use of an external potentiometer which can be located wherever convenient for the user. Remote muting is also useful for fire-alarm situations in which all unnecessary sound must be silenced. **The level controls adjust the level of the local input signals only. They do not adjust the Dante network audio signal level. This level must be adjusted at the signal source or via a network audio device.**



**NOTE: If the remote volume control connector is utilized, it will override the volume knob on the rear of the unit.**

In order to remotely control the volume of the unit, a 10k-ohm potentiometer should be placed between the +10V pin and the GND (Ground) pin on the rear of the unit with its wiper on the RVC pin. The volume will be determined by the selected resistance on the potentiometer, the greater the resistance the louder the volume.

The amplifier can be remotely muted by making a connection between the GND pin and the MUTE pin. No power should be applied to these pins, simply a contact connection.

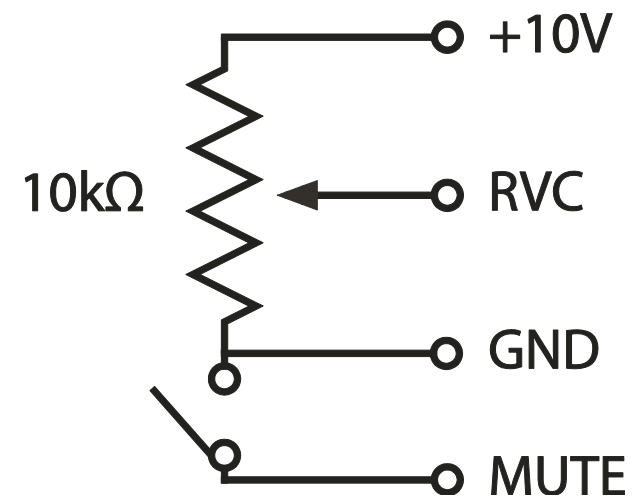

## 4 Troubleshooting

### **Problem: Power indicator does not turn on.**

**Procedure:** Check that the amplifier is plugged into a live outlet. After you have ensured that it is not a power issue, disconnect any speakers. If the amplifier turns on after a few seconds delay, then the problem is in the output connection. Check wiring and speakers for short circuits.

### **Problem: No output on one or both channels; Power indicator is lit.**

**Procedure:** Check that level controls are not turned down. Check that input and output connections are secure. Ensure signal present LED is flashing to denote a signal. If there is no signal detected check signal source and that level controls are set high enough.

### **Problem: Amplifier overheats and/or shuts off.**

**Procedure:** Review **section 2.3** on proper cooling procedures. Check the signal lights on the rear of the amplifier to see if the signal is overdriving (the signal light flashes red frequently). Overdriving the amplifier for extended periods of time can cause a thermal shutdown.

### **Problem: Output sound is distorted or cracking.**

**Procedure:** Check all cables for damage or loose connections and reduce the gain on the input signal at the mixer or preamp level. Replace the cables and loudspeakers temporarily to see if this resolves the problem. If problem still exists, contact your Authorized Dealer for service.

## 5 Technical Specifications

<b>Maximum Output 30Hz - 20kHz</b>	
Stereo	25W @ 8Ω per channel
	35W @ 4Ω per channel
<b>Frequency Response (+0, -3 dB)</b>	30Hz-20kHz
<b>Bandwidth +/- 3.0dB</b>	30Hz-30kHz
<b>THD+N</b>	<0.1%
<b>Signal to noise ratio</b>	>100dB
<b>External Mute</b>	Contact closure
<b>Slew Rate</b>	30V/ms
<b>Input Sensitivity</b>	0.5V (-3 dBV)
<b>Standard Voltage Gain</b>	28X (26.5dB)
<b>Input Impedance (Balance/Unbalanced)</b>	20k Ohms/10k Ohms
<b>Power Consumption: Idle; 1/8 Draw</b>	6.1 Watts; 14 Watts
<b>Class</b>	D
<b>Input Connectors</b>	RJ45, Euro Block (NET+)
<b>Output Connectors</b>	Euro Block
<b>Power Supply</b>	External In-Line 48VDC
<b>Cooling</b>	Convection-Cooling
<b>Controls</b>	Level (NET+)
<b>LED Indicators</b>	Power, Signal Present & Clip
<b>Construction</b>	Aluminum Chassis
<b>Dimensions</b>	
Height	1.25in (3.2cm)
Width	6in(15.2cm)
Depth	4in (10.2cm)
Weight	0.57lbs (0.26kg)

Stewart Audio reserves the right to change features and specifications without notice.

## 6 Warranty Information

### 6.1 Warranty Summary

All Stewart Audio amplifiers and accessories, unless excluded in this summary, are covered by a 3-year limited warranty on parts and labor from the date of purchase. In order to be eligible for warranty repairs, the amplifiers and accessories must have been purchased through an authorized Stewart Audio dealer and submitted by the original purchaser. This warranty is only valid in the country in which the amplifier was purchased.

#### 6.1.1 Eligibility Requirements.

Stewart Audio warrants against all malfunctions which come as a result of component or manufacturer defect. The amplifier is also covered from all failures which arise during the warranty period (3 years from date of purchase) that are not a result of misuse. The following actions will void your warranty:

- The power cord or AC plug has been damaged through misuse.
- The amplifier has been exposed to moisture or extreme temperatures.
- The amplifier has been dropped, items have been dropped on the amplifier, or the enclosure has been damaged.
- The amplifier has been opened by the operator.
- The amplifier was improperly packaged when sending to the factory for repair, resulting in damage.
- Any of the precautions or instructions found in this manual were not followed.

Damages resulting to the amplifier which are not covered under this warranty can be factory-repaired at cost to the customer. Use the contact information below to initiate the repair process.

### 6.2 Return Procedure

This section includes the return procedures which must be followed in order to prevent processing delay or cost to the customer. Please read the entire section before contacting Stewart Audio for returns.

#### 6.2.1 Return Authorization Number

All returns to the factory for service must be accompanied by a Return Authorization (RA) number. One can be obtained by contacting Stewart Audio at (209) 588-8111 or via e-mail at support@stewartaudio.com.

**NOTE: Any defective products received without an RA number will be returned to sender at their expense.**

If Stewart Audio is unable to contact the sender in 14 days, the merchandise will be considered scrap and may be disposed of.

#### 6.2.2 Shipment Instructions

If Stewart Audio requests that you ship the defective product back to their service center, please refer to the guide below. To ensure prompt warranty service, be sure to follow all instructions.

1. Return Authorization (RA) is required for product being sent to the factory for service.
2. See packing instructions in **section 6.2.3**.
3. Ship the defective product using a method which provides for order tracking or order confirmation. The service center is located at the following address:

Stewart Audio  
14335 Cuesta Court Suite C  
Sonora, CA 95370

4. Use a bold black marker and write the RA number on three sides of the box.
5. Record the RMA number for future reference. The RA number can be used to check the repair status.

#### 6.2.3 Packaging Instructions

Should Stewart Audio request that you ship your product to their service center, these instructions must be followed in order to ensure safe delivery. If they are not followed, Stewart Audio assumes no responsibility for damaged goods and/or accessories that are sent with your unit.

### 6.2.3 Packaging Instructions (cont.)

1. Please write the RA number on three sides of the box. Include the Stewart Audio RA number inside the box and a brief description of the problem.
2. You will be advised during the RA process what accessories should be included with the amplifier (Power supplies, connectors, cords, etc.). This is dependent on the failure assessment.
3. When shipping your amplifier, it is important that it has adequate protection. We recommend you use the original packing material when returning the product for repair. If you do not have the original box, see number 4.
4. If you provide your own shipping pack, the minimum recommended requirements for materials are as follows:
  - a. 275 P.S.I. burst test, Double-Wall carton that allows for 2-inch solid Styrofoam on all six sides of unit or 3 inches of plastic bubble wrap on all six sides of unit.
  - b. Securely seal the package with an adequate carton sealing tape.
  - c. Do not use light boxes or "peanuts".

**NOTE: Damage caused by poor packaging will not be covered under warranty.**

### 6.2.4 Estimate Approval

An estimate for all non-warranty repairs will be provided to the customer once the unit has been shipped to the factory. The customer is responsible to approve this estimate within 7 days. If the repairs are not approved within 14 days, Stewart Audio reserves the right to consider the unit scrap and may discard it.

### 6.2.5 Payment of Non-Warranty Repairs

Payment for non-warranty repairs must be submitted to Stewart Audio before the product will be returned to the customer.

## 7 Accessories

The following accessories are available from Stewart Audio for your amplifier.

All part numbers shown are Stewart Audio Part Numbers.

### **Mounting Brackets**

AV-POLE	Pole-mount bracket for AV Series amplifiers
AV-BRACKET	Universal mounting bracket for AV Series amplifiers

### **Connection Adapters**

ADPT-RCA	Mono Female RCA to male Euroblock.
ADPT-SUMRCA	Stereo Female RCA to male Euroblock.
ADPT-SUM35	Stereo Female 3.5mm to male Euroblock

### **Wall Plates**

WP-RVC-B	Wallplate with 10k potentiometer and knob for remote volume control (Black)
WP-RVC-A	Wallplate with 10k potentiometer and knob for remote volume control (Aluminum)

**To purchase these accessories or to see the full Stewart Audio product lineup, visit us at:**

**[www.stewartaudio.com](http://www.stewartaudio.com)**