

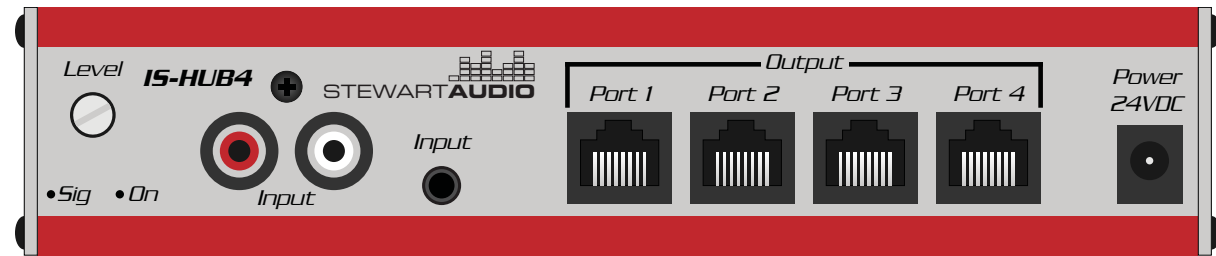

# STEWART **AUDIO**

The Difference is Hear

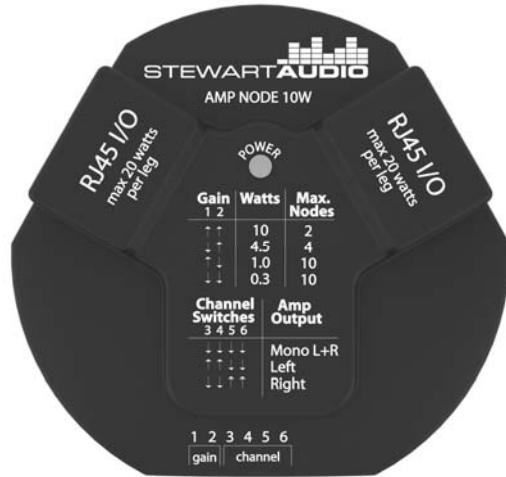

# IntraSound System

Owner's Manual  
February 2012

[www.stewartaudio.com](http://www.stewartaudio.com)

# Important Safety Instructions

Before using your Stewart Audio Inc. Power Amplifier, please read this **Owner's Manual** carefully to ensure optimum trouble-free performance.

**WARNING: TO REDUCE THE RISK OF ELECTRICAL SHOCK, DO NOT EXPOSE THIS AMPLIFIER TO RAIN OR MOISTURE. DANGEROUS HIGH VOLTAGES ARE PRESENT INSIDE THE ENCLOSURE. DO NOT OPEN THE CABINET. REFER SERVICING TO QUALIFIED PERSONNEL ONLY.**

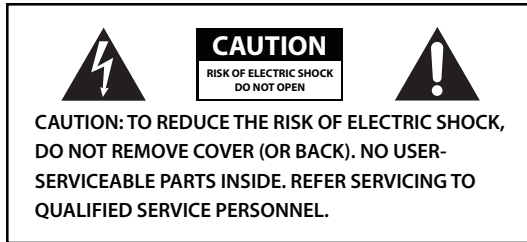

The lightning bolt within arrowhead symbol, within an equilateral triangle, is intended to alert the user to the presence of un-insulated "dangerous voltage" within the product's enclosure that may be of sufficient magnitude to constitute a risk of electrical shock to person.



The exclamation point within an equilateral triangle, is intended to alert the user to the presence of important operating and maintenance (servicing) instruction in the literature accompanying the appliance.

1. Read these instructions. All of the safety and operating procedures should be read before the amplifier is installed or operated.
2. Keep these instructions. Retain these documents for future reference.
3. Heed all warnings. All warnings on the amplifier and in these operating instructions should be adhered to.
4. Follow all instructions

5. Do not use this apparatus near water. For example, near a bathtub, in a wet basement, near a swimming pool, etc. This amplifier is intended to be operated in a controlled indoor environment.
6. Clean only with dry cloth. Do not use solvents or abrasive cleaners. Never pour any liquid on the amplifier.
7. Installation should be performed by a trained and licensed professional to insure safe and lasting operation.
8. Do not install near any heat sources such as radiators, heat registers, stoves, or other apparatus (including amplifiers) that produce heat.
9. Protect the power cord from being walked on or pinched particularly at plugs, convenience receptacles, and the point where they exit from the apparatus.
10. Unplug this apparatus during lightning storms or when unused for long periods of time.
11. Only use attachments/accessories specified by the manufacturer.
12. Refer all servicing to qualified service personnel. Servicing is required when the apparatus has been damaged in any way, such as power-supply cord or plug is damaged, liquid has been spilled or objects have fallen into the apparatus, the apparatus has been exposed to rain or moisture, does not operate normally, or has been dropped.
13. The 24 Volt DC power supply that is supplied with the IntraSound System may be connected to 120 to 240 VAC, 50-60 Hertz. Do not defeat the ground polarization of the power plug.

# Table of Contents

Important Safety Instructions.....	2
Table of Contents.....	4
<b>1 Welcome</b> .....	5
<b>2 System Overview</b> .....	6
<b>3 System Installation</b> .....	8
<b>4 Operation</b> .....	12
<b>5 Troubleshooting</b> .....	14
<b>6 Technical Specifications</b> .....	15
<b>7 Warranty Statement</b> .....	16
<b>8 Accessories</b> .....	16



# 1 Welcome



Congratulations on the purchase of your new Stewart Audio IntraSound System. If after reading this manual you should have any questions concerning amplifier installation and operation, please contact your Authorized Stewart Dealer, or you may contact us directly using the contact information provided on the back of this manual.

## 1.1 Features

Your Stewart Audio IntraSound System is the result of years of experience in the design and manufacture of quality amplifiers. As such it provides a combination of performance and operational benefits that simply cannot be found in conventional amplifiers.

- Distributes audio and power over Cat5 cables
- Compact hub and subcompact nodes
- Nodes have selectable wattage and channels
- Efficient Class D microamplifier inside every node
- Clean full-range dynamic power
- Signal Sense Technology for Energy Star Compliance
- Easy to install distributed audio solution
- External inline power supply

## 1.2 Using this Manual

In order to obtain maximum performance from your IntraSound System, please take time to read this brief owner's manual and carefully follow the guidelines for connection and operation.

This manual provides you with the information necessary to safely install and operate your new IntraSound System in the most common scenarios. If you find yourself requiring additional assistance, please feel free to contact your Authorized Dealer, or you may contact us directly using the information provided on the back of this manual.

## 2 System Overview

The IntraSound System by Stewart Audio consists of two key components: the IS-HUB4 and the IS-AmpNode-10. Other components such as Cat5 cable and speakers play a role in the system but will not be the focus of this manual.

### 2.1 System Components & Dimensions

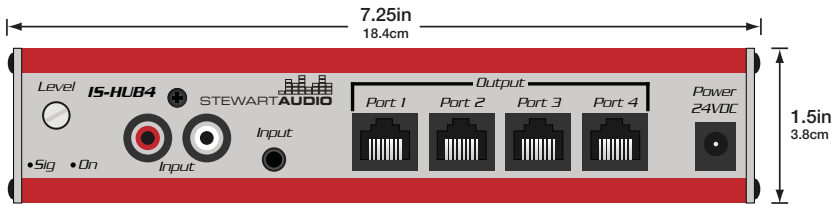

Hub Front

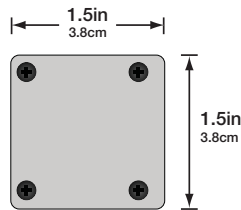

Hub Side

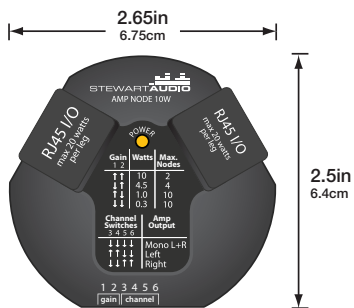

Node Top

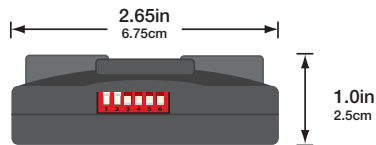

Node Side

### 2.2 Example System Setup

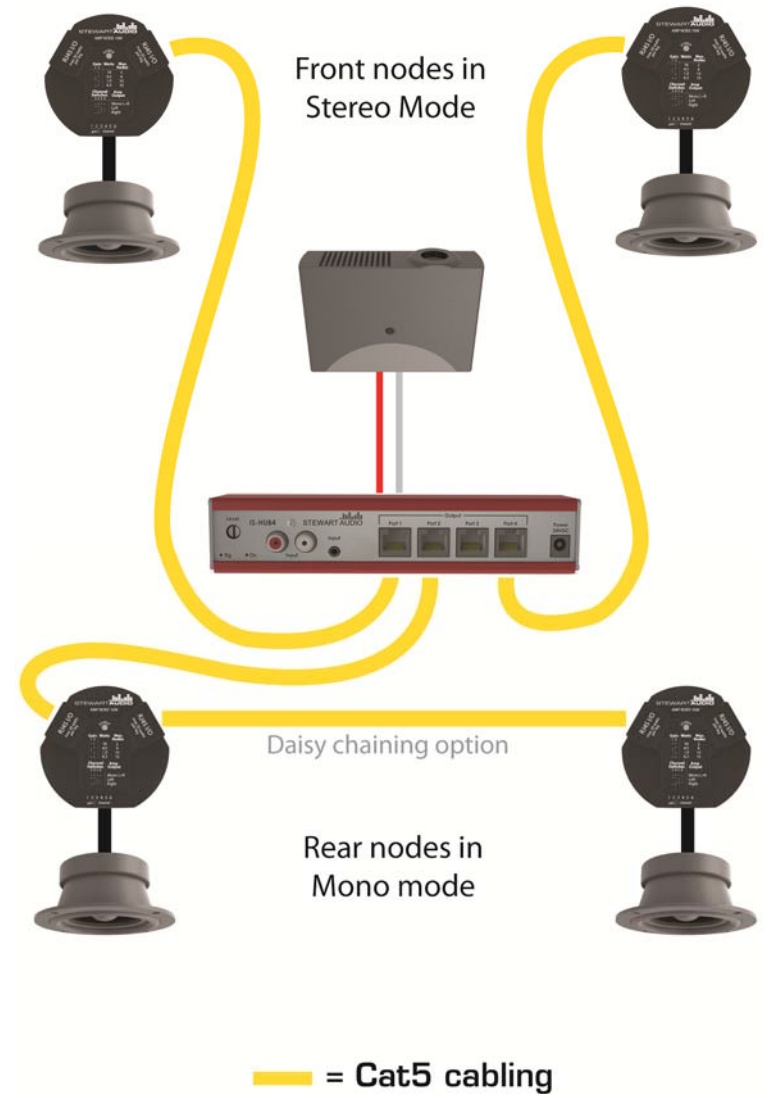

# 3 System Installation



**CAUTION: Before installing your system, make sure that you have read the Important Safety Precautions at the beginning of this manual.**

## 3.1. Hub Installation

Stewart Audio recommends that the unit is secured in some fashion to prevent movement of the unit if one of the cables is pulled during installation of an amplifier node.

### 3.1.1 Input Connections

The IS-HUB4 accepts an unbalanced stereo input using either RCA or 3.5mm plugs. The standard wiring is shown below.

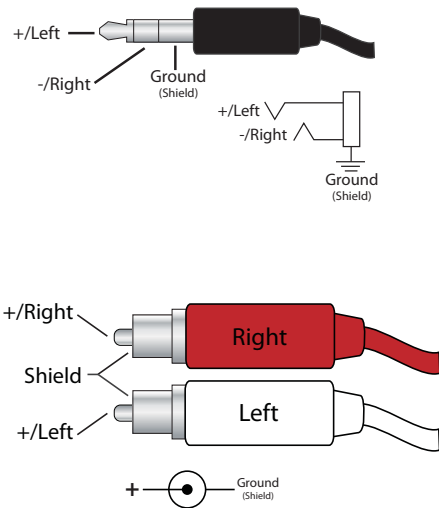

### 3.1.2 Output Connections

The IS-HUB4 utilizes standard Cat-5 (or Cat-5e) cable to send both signal and power to the nodes connected to its ports. Regular Cat-5 patch cables may be used, purchased in standard lengths or cut and crimped for the installation. If making your own cables, standard A or B patch cable wiring can be used or straight through connections between pin 1-8 to pin 1-8 on either end. **Crossover cables or wiring cannot be used.**

Each port is capable of outputting a maximum of 20 total watts of power to the nodes daisy chained on that port.



**CAUTION: Do not connect the Hub or Amp Nodes to any other devices (such as a network router or switch). They are not internet capable and will damage other devices.**

The total power output of the IS-HUB4 is limited by the power rating of the power supply which was purchased with the system and cannot exceed 80 Watts.

Each IS-Hub4 port is capable of outputting a maximum of 20 watts of speaker power. This 20 watts is available for the IS-AmpNode-10/ speakers daisy chained to the port.

If you would like to upgrade the chosen power supply, please contact your local sales rep for details.

## 3.2 Node Installation

The IS-AmpNode-10 contains a single channel micro amplifier capable of delivering up to 10 watts of power to a single speaker.

If you have purchased the IS-SP4 speakers as a part of your IntraSound system, the amplifier can be secured into the top of the speaker. To secure the amplifier node, place the node on top of the speaker inserting the screws on the top of the speaker into the notches on the rear of the amplifier. Twist the node clockwise and it will lock into place.

To secure the amplifier node to another type of speaker, Stewart Audio recommends industrial strength Velcro for easily installation.

### 3.2.1 Node Input Connections

The IntraSound system utilizes Cat5 to send power as well as a stereo signal to each node on the line. For the initial connection between the IS-HUB4 and an IS-AmpNode-10, a Cat5 cable should connect any port on the hub with either the left or right port of the node. The remaining port of the node can be used to daisy chain it to another node

**Caution:** Do not connect the final node in a line back to the IS-HUB4. Doing so may damage the hub.

### 3.2.2 Amplifier Node Configuration

The Amp nodes are configured on a node-per-node basis using the DIP switches located on the front of the node. This can be done with a small screwdriver or other tool that will fit into the recessed switches. The configuration options are found printed on the top of the amplifier or below

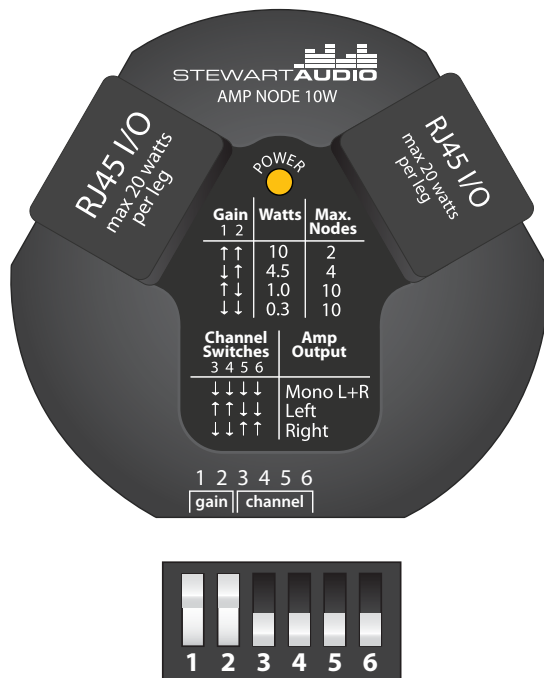

In this example, the node is set to 10W and Mono L+R

### Gain Configuration

The gain level on the micro amplifier nodes is adjustable from 0.3W to 10W using the DIP switches on the front of the unit. Using the table printed on the top of the node or provided for you on the left, adjust the first 2 DIP switches to the desired setting.

**Note:** Each port from the hub is capable of supplying 20W each. This means that the higher the gain setting, the fewer units you can daisy chain. Refer to the table below.

Selected Wattage	# of Units/Port
10W	2
4.5W	4
1.0W	15*
0.3W	50*

\*Number reduced to account for power loss over cable

### Channel Configuration

When the signal is sent down the Cat5 cable from the hub to the nodes, both the left and right channels are sent. This means that each amplifier node can be configured to output the left channel, right channel, or a mono summation. The last 4 switches of the DIP switch are for selecting the channel.

Refer to the image in section 3.2.2 or the silkscreen of the amplifier node for switch configurations.

**Note:** Each port from the hub is capable of supplying 20W each. This means that the higher the gain setting, the fewer units you can daisy chain. Refer to the table below.

# 4 Operation

## 4.1 Operating Precautions

1. Before use, your amplifier must be configured for proper operation, including input and output wiring hookup. Improper wiring can result in damage to equipment or potentially harm to the operator. Consult **section 3** for setup instructions.
2. Tampering with the circuitry, or making unauthorized changes is not only dangerous but may also violate local regulations.
3. Use care when making connections between the amplifier and the input or output equipment. Using equipment that is not capable of handling the output wattage may lead to permanent damage.



**NOTE: Stewart Audio will not be held responsible for damage to your IntraSound System or connected equipment if the instructions in this manual are not followed.**

## 4.2 Indicators and Controls

### 4.2.1 Indicators and Controls on IS-HUB4

The IS-HUB4 accepts all inputs and power and sends it down Cat5 cable to the amplifier nodes. All power and system volume can be controlled on the IS-HUB4.

Two LED indicators on the left-hand side of the IS-HUB4 will illuminate when power is supplied (Power LED - blue) and when signal is detected on either input (Sig LED - green). If the nodes are not outputting any audio, first check to make sure that both of these LEDs are illuminated.

**Note - When the IS-HUB4 goes into sleep mode due to no signal, the LED will turn OFF. To turn the IS-HUB4 back on, make sure that signal is being sent to the IS-HUB4.**

The system volume can be set using the recessed knob on the left-hand side of the unit. To turn this, insert a small screwdriver into the slot and turn clockwise to turn the volume up.

### 4.2.2 Indicators and Controls on IS-AmpNode-10

The IS-AmpNode-10 has an amber LED on the top of the node which will illuminate when power is supplied to the node from the hub.

**Note - When the IS-HUB4 is in sleep mode, the amber LED indicators on the top of the amplifier nodes will turn off.**

To control the wattage of the amplifier, refer to **section 3.2.2**.

## 5 Troubleshooting

### Problem: Hub's Power indicator does not turn on.

**Procedure:** Check that the hub is plugged into a live outlet. After you have ensured that it is not a power issue, check that you have a hot signal going into the inputs. If a signal is not detected, the hub will go into a sleep mode after 5 minutes to comply with Energy Star.

### Problem: Amplifier Node's power indicator does not turn on.

**Procedure:** First check to make sure that the power indicator is lit on the hub, if not then see the corresponding Troubleshooting entry. If this does not resolve the issue, then double-check the Cat5 cable going from the hub to the amplifier node. Replace this cable if possible. If this is not the issue, then ensure that you are not stringing too many nodes on a line. Refer to **section 3.2.2** for more information on this.

### Problem: Amplifier Node is outputting *no* audio.

**Procedure:** First check that the signal indicator on the hub is lit and the volume control is at a reasonable level on the hub. Next, to rule out a cabling issue, check that the power indicator is lit on the amplifier node. If this does not resolve the issue then refer to **section 3.2.2** to ensure that the DIP switches are correctly configured on the node. If all of the channel selection switches are in the "up" position, then this is most likely the issue. Refer to **section 3.2.2** for the proper settings.

### Problem: Amplifier Node is outputting weak audio

**Procedure:** First check the Level knob on the hub to make sure it is at a reasonable level. Next, check the DIP switches on the front of the amplifier node to see what the gain is set at. If both switches are in the "up" position and you still have a weak output, check to make sure that you are not stringing too many nodes on a line. Refer to **section 3.2.2** for more information on this.

## 6 Technical Specifications

<b>Maximum Output 20Hz - 20kHz</b>	
Output per node	10W @ 8Ω
Hub's Total Output	Wattage of power supply
<b>Frequency Response (+0, -3 dB)</b>	20Hz-20kHz
<b>THD+N</b>	<0.1% at 1W
<b>Signal to noise ratio</b>	>100dB
<b>Standard Voltage Gain</b>	Adjustable 20-36dB
<b>Input Impedance (Unbalanced)</b>	9-60kΩ (Depending on gain)
<b>Sleep, Idle (No Nodes)</b>	0.005/0.016A
<b>Class</b>	D
<b>Input Connectors</b>	3.5mm Stereo, Dual RCA
<b>Output Connectors</b>	RJ-45 (Hub), Bare wire (Node)
<b>Power Supply</b>	External In-Line 24VDC
<b>Cooling</b>	Convection-Cooling
<b>Controls</b>	Master Volume (Hub), Gain and Channel Select (Node)
<b>LED Indicators</b>	Power & Signal Present
<b>Construction</b>	Aluminum Chassis (Hub), ABS Plastic (Node)
<b>Dimensions</b>	
Height	1.25in (3.2cm)
Width	4.35in (11.1cm)
Depth	3.2in (8.1cm)
Weight	0.37bs (0.16kg)



# 7 Warranty Information

## 6.1 Warranty Summary

All Stewart Audio amplifiers and accessories, unless excluded in this summary, are covered by a 3-year limited warranty on parts and labor from the date of purchase. In order to be eligible for warranty repairs, the amplifiers and accessories must have been purchased through an authorized Stewart Audio dealer and submitted by the original purchaser. This warranty is only valid in the country in which the amplifier was purchased.

### 7.1.1 Eligibility Requirements.

Stewart Audio warrants against all malfunctions which come as a result of component or manufacturer defect. The amplifier is also covered from all failures which arise during the warranty period (3 years from date of purchase) that are not a result of misuse. The following actions will void your warranty:

- The power cord or AC plug has been damaged through misuse.
- The amplifier has been exposed to moisture or extreme temperatures.
- The amplifier has been dropped, items have been dropped on the amplifier, or the enclosure has been damaged.
- The amplifier has been opened by the operator.
- The amplifier was improperly packaged when sending to the factory for repair, resulting in damage.
- Any of the precautions or instructions found in this manual were not followed.

Damages resulting to the amplifier which are not covered under this warranty can be factory-repaired at cost to the customer. Use the contact information below to initiate the repair process.

## 7.2 Return Procedure

This section includes the return procedures which must be followed in order to prevent processing delay or cost to the customer. Please read the entire section before contacting Stewart Audio for returns.

### 7.2.1 Return Authorization Number

All returns to the factory for service must be accompanied by a Return Authorization (RA) number. One can be obtained by contacting Stewart Audio at (209) 588-8111 or via e-mail at support@stewartaudio.com.

**NOTE: Any defective products received without an RA number will be returned to sender at their expense.**

If Stewart Audio is unable to contact the sender in 14 days, the merchandise will be considered scrap and may be disposed of.

### 7.2.2 Shipment Instructions

If Stewart Audio requests that you ship the defective product back to their service center, please refer to the guide below. To ensure prompt warranty service, be sure to follow all instructions.

1. Return Authorization (RA) is required for product being sent to the factory for service.
2. See packing instructions in **section 7.2.3**.
3. Ship the defective product using a method which provides for order tracking or order confirmation. The service center is located at the following address:

Stewart Audio  
14397 Cuesta Court Suite D1  
Sonora, CA 95370

4. Use a bold black marker and write the RA number on three sides of the box.
5. Record the RMA number for future reference. The RA number can be used to check the repair status.

### 7.2.3 Packaging Instructions

Should Stewart Audio request that you ship your product to their service center, these instructions must be followed in order to ensure safe delivery. If they are not followed, Stewart Audio assumes no responsibility for damaged goods and/or accessories that are sent with your unit.

### 7.2.3 Packaging Instructions (cont.)

1. Please write the RA number on three sides of the box. Include the Stewart Audio RA number inside the box and a brief description of the problem.
2. Do not ship any accessories (manuals, cords, hardware, etc.) with your unit. These items are not needed to service your product. Stewart Audio will not be held responsible for these items if they are returned with the amplifiers.
3. When shipping your amplifier, it is important that it has adequate protection. We recommend you use the original packing material when returning the product for repair. If you do not have the original box, see number 4.
4. If you provide your own shipping pack, the minimum recommended requirements for materials are as follows:
  - a. 275 P.S.I. burst test, Double-Wall carton that allows for 2-inch solid Styrofoam on all six sides of unit or 3 inches of plastic bubble wrap on all six sides of unit.
  - b. Securely seal the package with an adequate carton sealing tape.
  - c. Do not use light boxes or "peanuts".

**NOTE: Damage caused by poor packaging will not be covered under warranty.**

### 7.2.4 Estimate Approval

An estimate for all non-warranty repairs will be provided to the customer once the unit has been shipped to the factory. The customer is responsible to approve this estimate within 7 days. If the repairs are not approved within 14 days, Stewart Audio reserves the right to consider the unit scrap and may discard it.

### 7.2.5 Payment of Non-Warranty Repairs

Payment for non-warranty repairs must be submitted to Stewart Audio before the product will be returned to the customer.

## 8 Accessories

***At the time of this printing, the IntraSound System accessories were still under development***

**To view the IntraSound System accessories or to see the full Stewart Audio product lineup, visit us at:**

**[www.stewartaudio.com](http://www.stewartaudio.com)**